



AirHeat Burners

AH-MA Series

Version 2.20

Main Specifications

Parameter	Description
Input (Btu/hr./ft.)	1,200,000 maximum
Combustion Airstream Pressure Drop/Velocity	0.2" to 1.4"w.c.
Ignition	Direct spark ignition (6000VAC).
Pilot	Interruptible pilot for natural gas, propane or butane.
Integral Pilot Capacities	20,000 Btu/hr.
Burner Bodies	Standard Aluminum Low Pressure Aluminum* Standard Cast Iron Corrosion Resistant, EN Plated Cast Iron Low Pressure Cast Iron*
Burner Section Sizes	<ul style="list-style-type: none"> • 150mm (6") straight section • 300mm (12") straight section • 300mm (12") straight section with back inlet • 300mm (12") straight section with pilot • 150mm (6") by 300mm (12") tee section • 150mm (6") by 300mm (12") tee section with pilot • 300mm (12") by 300mm (12") cross section
Pipe Threads	N.P.T. or B.S.P.
Maximum Upstream Air Temp.	450°F (232°C)
Maximum Downstream Air Temp.	850°F (454°C)
Maximum Temperature Rise	750°F (400°C)
Minimum Inlet Air Oxygen (O ₂)	18%
Flame Detection**	Flame rod or scanner.
Fuels	Natural gas, propane or butane.

* For use with Natural Gas only.

** Burners over 5 lineal feet include flame supervision at the far end. If pilot ignition is being used, two flame supervision units are required; one for the pilot and one for the far end. If using direct spark on the main flame, only flame supervision at the far end is required providing ignition can be accomplished within 15 seconds. (Reference NFPA Requirement 5-9.2.2)

- Eclipse reserves the right to change the construction and/or configurations of our products at any time without being obliged to adjust earlier supplies accordingly.
- All information is based on laboratory testing. Different chamber size and air flow conditions may affect the data.
- All information is based on standard conditions (70°F at sea level). Contact Eclipse for performance data above ambient temperature.
- All inputs based on gross caloric values.

Operating Range & Duct Pressure Measurement

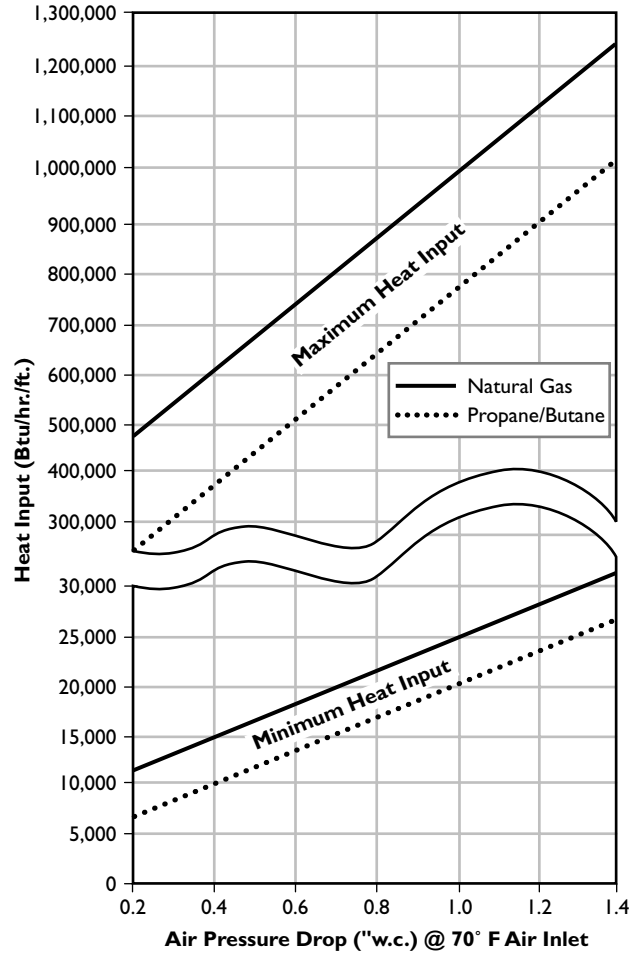

Inlet Air Temperature Correction

Air Press. Drop @ Air Temp. = Air Press. Drop from "Oper. Range" Chart x Correction Factor										
Air Inlet Temp. (°F)	0	30	70	150	200	250	300	350	400	450
Correction Factor	0.87	0.92	1.00	1.15	1.25	1.34	1.43	1.53	1.62	1.72

Air Velocity Calculation

$$\text{Air Velocity (fpm)} = 1096.2 \sqrt{\frac{\text{Air Pressure Drop ('w.c.)}}{\text{Air Density (lbs./cubic ft.)}}}$$

Differential Pressure Measurement & Burner Gas Pressure Drops

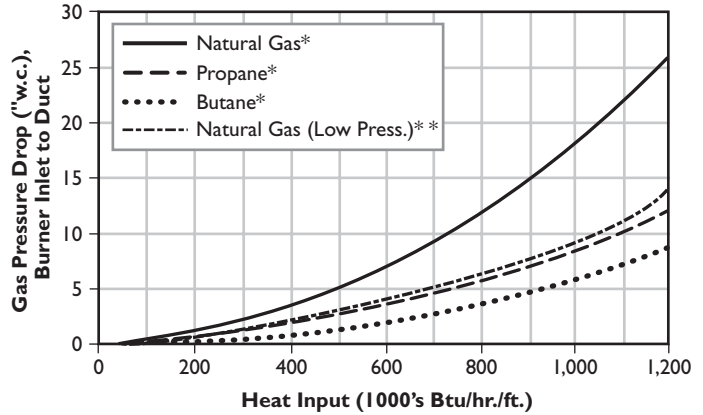
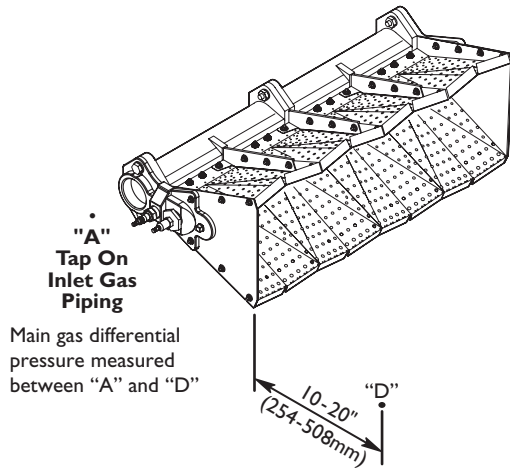

* 2.0mm gas ports.
 ** 2.4mm gas ports

Flame Lengths

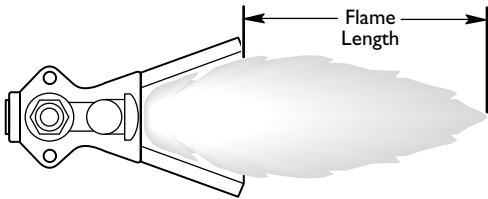

Note:
 Flame length may vary slightly from these values depending on actual fuel, air handling system, duct configurations and profile plates uses.

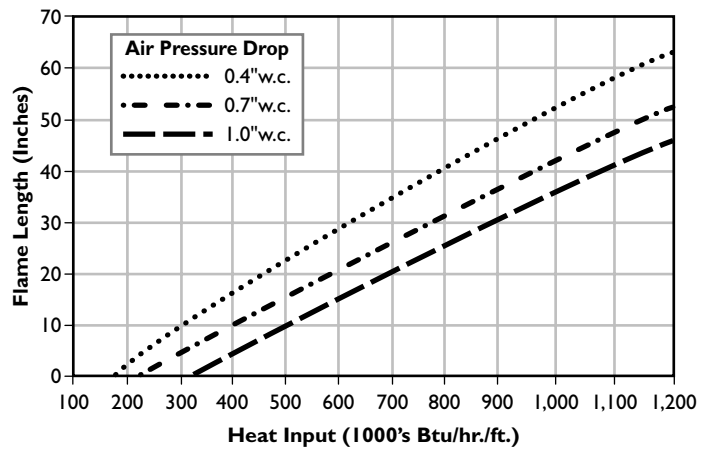

Emissions Data

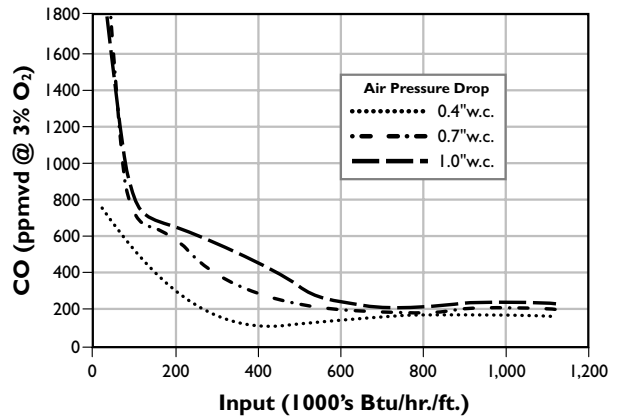
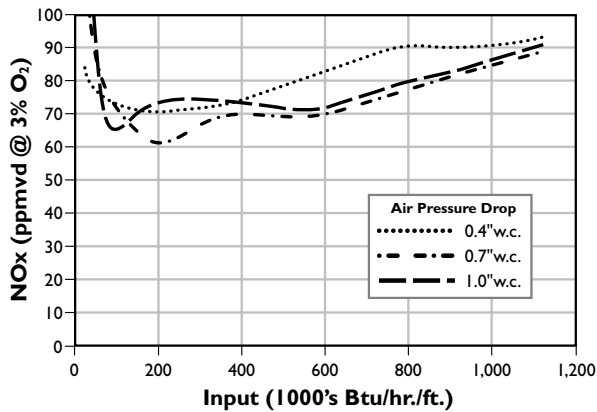



Eclipse Combustion

www.eclipsenet.com