



TABLE OF CONTENTS – SCISSOR LIFTS

FOREWORD _____	3
SPECIFICATIONS _____	4
EQUIPMENT ARRIVAL _____	5
INSTALLATION _____	6
OPERATIONAL INSTRUCTION _____	7
SAFETY _____	8
MAINTENANCE _____	9-13
WARRANTY _____	14
PARTS RETURN POLICY _____	15
SUGGESTED SPARE PARTS _____	16-17
REFERENCE DRAWINGS/PHOTOGRAPHS _	18-25
HYDRAULIC/PNEUMATIC SCHEMATICS _	26-28

SAFETY ALERTS



**KNOW AND UNDERSTAND YOUR SAFETY SYMBOLS AND ALERTS!
ACCIDENTS CAN BE AVOIDED, SAFETY IS VERY IMPORTANT TO US,
IT SHOULD BE VERY IMPORTANT TO YOU!**

Follow instructions on safety tags on your equipment. Your safety is of great concern, so please be alert to warnings, cautions and notes. Labels on equipment and in this manual are intended to make you aware of possible safety issues. When you see this symbol, be alert to the possibility of personal injury or death.

DANGER – Death, personal injury or property damage **WILL** be the result if you fail to follow instructions.

WARNING – Death, personal injury or property damage **COULD** be the result if you fail to follow instructions.

CAUTION – Damage to equipment **COULD** be the result if you fail to follow instructions.

NOTE – Information to further explain operations or instructions.

FOREWORD

Titan Air has manufactured the highest quality air makeup systems since 1983 and has carried over this commitment to excellence in the manufacturing of personnel lifts. Quality, technology and teamwork have enabled us to set standards of excellence. We believe that our obligation to our customers goes beyond providing them with a high quality product. We must also provide the highest quality product support and warranty. We pledge to continue improvements through the use of customer input and new technologies that become available. As our valued customer, we realize that you have come to expect nothing less.

Manuals for Titan Lifts will be an on going and improving process as we strive to supply the best features available.

If we have overlooked something, if some information is incorrect, or if you have comments on printed material which may make our Titan Lift a better product, contact us. Your opinions do matter!

TITAN SCISSOR LIFT

SPECIFICATIONS

ANSI A92.6-1999 & OSHA Compliant Self-Propelled Elevating Work Platform

1. **X – AXIS TRAVEL – HORIZONTAL TRAVEL OF THE LIFT.**

The lift is driven by one aluminum wheel direct coupled to a hydraulic motor. The hydraulic motor is driven by the hydraulic pump & air motor that also powers the dual lift cylinder. The design speed in both directions is 40 Ft. per minute. (See Figure 1 in Drawings & Photographs.)

2. **Y – AXIS ROLL OUT– HORIZONTAL TRAVEL OF BASKET**

This lift is provided with a manual roll-out system. The basket is designed with a secondary platform capable of moving out an additional 18” on the working side of platform. The cantilevered deck moves in and out by pushing or pulling the secondary platform & locking the deck in either position with locking pins provided on both sides of the hand rails.

2. **Z – AXIS TRAVEL – VERTICAL TRAVEL OF BASKET**

The maximum vertical travel of the lift basket from floor to basket floor is 9 Ft. 6in.

The lift travel is accomplished by means of a hydraulic pump driven by an air motor. (See Figure 2 in Drawings & Photographs.) The hydraulic pump drives the dual cylinders which in-turn raises the scissor lift platform. The descent of the platform is gravity descent and velocity fuses provided on both cylinders prevent uncontrolled drop in the event of a hose failure. The rate of speed is designed at 15 ft. per minute.

4. **OPERATOR BASKET CONTROLS**

The control panel for basket movement is located on the front (door side) of the basket. The controls are “joy stick” valves that are moved in the direction of desired travel and will spring return to stopped position when released. The Emergency Down valve is included to lower the basket in the event of an air supply loss. The E-Down valve is located at the unit base opposite the ground control. Ground control is also provided to allow the raising or lowering the basket from ground level (see photograph).

5. **UTILITIES**

Each Titan Lift requires an air supply of 80 CFM at 100 PSI of clean, dry air. All internal components are provided with the lift and only one point of connection is required. The internal components include all of the piping, tubing, valves, hydraulic/pneumatic switches, filter/regulator/lubricator and safety lock-out valve for required maintenance. The single air supply source will be provided through a festooning system.

TITAN SCISSOR LIFT *EQUIPMENT ARRIVAL*

When the trucker arrives with your Titan Lift, inspect the equipment for damage. The equipment has been inspected and tested before leaving the factory. Read the bill of lading and verify that the items listed are what you have received. Any damage or missing items should be reported to the shipper immediately. DO NOT SEND DAMAGED FREIGHT BACK TO THE FACTORY.

All claims must be filed with the shipper. It is recommended to take photographs and get the driver's signature to confirm the damage. Request a written inspection report from the claims inspector to substantiate any necessary claim. Notify Titan Air Inc. of the damage and order replacement parts if needed.

If for some reason you are unable to install the equipment immediately, protect the equipment from the elements. Water damaged parts are not covered under Titan's warranty. If the lift is to be stored beyond 60 days, protective measures should be taken to preserve the integrity of the lift.

Read the product warranty, installation and operating instructions before installing the equipment. Titan Air Inc. offers installation supervision and on-site training for a pre-determined fee.

TITAN SCISSOR LIFT

INSTALLATION

1. BOTTOM RAIL INSTALLATION:

It is very important to maintain parallelism between the bottom track rail and the spray booth wall. Any excessive misalignment will cause potential damage to the lift or spray booth wall. The clearance between the extreme dimension of the lift and spray booth wall has been provided.

2. LIFT INSTALLATION:

- A. Upon completion of the bottom rail installation, the lift can be positioned onto the rail. The lift has two grooved aluminum wheels with profiles cut to match the profile of the square tubing used as a bottom rail. One of the two grooved wheels is the drive wheel for horizontal travel.
- B. Attach any items such as rail scrapers, paint pot carriers, etc. that is required for operation of the lift.

4. UTILITIES

- A. Each Titan Lift requires an air supply of 80 CFM at 100 PSI of clean, dry air. Attach the air supply hose (supplied with unit) to the mast provided with the lift. The vertical mast is bolted to the base frame and acts as a air chamber for the air supply required to operate the lift. This is the only connection required to make the lift operable. (See Figure 3 in Drawings & Photographs.) This installation will require the mast locations to be right and left hand.

NOTE: Connect the air hose avoiding any kinks or bends that would restrict the air flow to the unit.

- B. Fill the air lubricator located at the base of the lift with oil supplied with the unit.

5. LOAD RATING

- A. The maximum live load allowance in the basket with the roll-out retracted is 600 lbs. This load includes the operator(s) and all related equipment in the basket. With the roll out fully extended – 18 in. The rated load capacity is 600 lbs.

6. AIR MAST

- A. The air mast provided must be bolted to the base. This had to be removed for shipment. (See Figure 3 in Drawings & Photographs.)

TITAN SCISSOR LIFT

OPERATIONAL INSTRUCTIONS

ALL OPERATING AND MAINTENANCE PERSONNEL MUST BE TRAINED ON THE TITAN LIFT.

1. The basket has a total maximum weight capacity of 600 pounds with the roll-out retracted or extended.
2. Connect the air supply hose to the air mast once installed. The mast has a sleeve welded to the top for supporting the air hose coming from the festooning to prevent hose from excessive bending or kinking.
3. With the air supply connected, slowly open the main air supply shutoff valve (See Figure 4 in Drawings & Photographs). Once the air supply is turned on, confirm the air pressure air regulator is set at 100 PSI. The lift is then ready to operate. Make sure the lubricator has been filled.
4. There are two locking devices on each side of the basket (See Figure 6 in Drawings & Photographs). Both of these locking devices must be engaged in either the retracted or extended position.
5. The operator must stay in the basket with the spring loaded access door completely closed and the roll out locking device engaged on both sides of basket. When entering the basket, it is very important to have the locking devices engaged to prevent the basket roll out from moving out.
6. Operating the basket – the lift is very simple to operate. The axis movement is controlled by the respective “joystick” and in the direction of desired travel which is vertical travel (UP/DOWN) or horizontal travel (LEFT/RIGHT) this movement is labeled on the respective “joystick (See Figure 5 in Drawings & Photographs). When the basket has reached full travel or stroke, the basket will stop.
7. **OTHER LIFT CONTROLS**
 - a. EMERGENCY STOP – The e-stop is located on the basket control panel and ground control. These e-stops will shut off the air supply to all axis controls. This is a simple push/pull button (red). Push to activate and pull to reset (See Figure 5 in Drawings & Photographs).
 - b. EMERGENCY DOWN – This control valve allows the basket to be lowered when the main air supply to the lift is interrupted. This control is activated by simply turning the valve counterclockwise. After the lift is fully lowered, close the valve by turning it clockwise. (See Figure 7 in Drawings & Photographs.)
 - c. SAFETY SHUT OFF VALVE – The lift is equipped with a lockable safety shut off valve which will turn off the air supply to the unit. This will completely disable the Titan Lift which will allow the required maintenance or repairs. Rotate the valve handle 90 degrees or perpendicular to air flow.
 - d. This will exhaust all air pressure from the system. It is recommended that lockout/tag out procedures be followed.
 - e. During maintenance and when the lift is raised, it is very important to install a block between the lower arm cam roller & the end of the cam way channel to prevent the scissors arms from moving. These blocks should be installed on both sides of frame.

TITAN SCISSOR LIFT

SAFETY

Safety is the single most important feature that must be taken into consideration when developing, manufacturing and operating a product. Titan has taken many precautions to assure that the product offered is the safest it can be. It should be noted that a machine can be the safest in the world but if the operator does not operate or maintain it properly, the safety that has been built into the machine will be compromised.

The following is a list of DO'S and DON'TS that must be followed:

DO read the operation and maintenance manual completely prior to operating the lift for the first time.

DO use care, caution, and common sense when operating your Titan lift.

DO check all lifting clearance.

DO use safety devices at all times. Leave all guards and screens in place.

DO use caution and relieve the pressure before opening any pressurized system or lines.

DO remember that failure to follow safety precautions could result in injury or death.

DO periodically clean warning labels and replace them if they become damaged.

DO start and maintain a regular maintenance program. Failure to do so will reduce the life span of the lift.

DO NOT attempt to get off the lift unless it is in the fully lowered and retracted position.

DO NOT operate the lift if it is damaged or not running properly.

DO NOT place over 600 pounds (This includes lift operator) in the standard basket and **DO NOT** attempt to service the lift unless it is fully lowered and air supply is shut off. (If lift must be raised for service, the assembly **MUST** be securely supported, so it can not descend)

DO NOT allow the lift to become excessively dirty. Periodically clean off paint over spray and/or debris that may accumulate.

TITAN SCISSOR LIFT

MAINTENANCE

1. **TROUBLE SHOOTING** – YOUR TITAN LIFT IS DESIGNED AND BUILT TO GIVE YEARS OF TROUBLE FREE SERVICE. HOWEVER, BECAUSE MECHANICAL PARTS CAN AND DO FAIL, PROBLEMS MAY OCCUR. LISTED BELOW IS A TROUBLE SHOOTING GUIDE WHICH WILL ASSIST IN DIAGNOSIS AND RESOLUTION TO THE PROBLEM.

<i>PROBLEM & CAUSE</i>	<i>SOLUTION</i>
1. <u>Lift Will Not Operate.</u>	
Main air supply off or line pinched.	Turn on air supply or check hoses.
Air pressure regulator needs adjustment.	Adjust air regulator.
Base or basket E-Stop depressed	Reset E-Stop
System Control key is off	Turn key to ON position
Plugged air filter.	Replace or clean filter.
2. <u>Lift Operates Slow or Intermittent.</u>	
Air supply line is pinched.	Inspected all air lines.
Low air pressure or air supply	Regulator must be set at 100 PSI- Air supply must consistently deliver 80 SCFM at 100 PSI.
High moisture content in air supply.	Inspect air dryer on compressor.
Plugged air filter or mufflers.	Clean or replace.
Lack of lubrication.	Lubricate all zerks.
Insufficient air lubrication.	Check fluid level and drip rate of lubricator.
3. <u>Basket Will Not Move Vertically.</u>	
Z-axis shuttle valve malfunction.	Replace.
Pilot valve not shifting	Check for pilot air pressure Repair or replace
Air Motor not turning	Replace Air Motor
Hydraulic Pump not operating	Check Coupling between air motor Replace hydraulic pump

TITAN SCISSOR LIFT MAINTENANCE

- | | |
|---|--|
| 4. <u>Erratic or Loss of Vertical Control.</u> | |
| Leaking valve. | Repair or replace. |
| Pilot valve or shuttle valve sticking. | Replace. |
| 5. <u>Basket Will Not Descend.</u> | |
| Descend flow control set above velocity fuse rating | Decrease flow control setting |
| Loss of pilot air pressure | Check for air flow to down valve from main panel |
| 6. <u>Slow or Erratic Movement Along Rails</u> | |
| Rails obstructed or rail joints not smooth. | Clean rails or grind rail joints. |
| Hydraulic motor coupling disengaged | Replace coupling |
| Hydraulic motor not functioning | Replace hydraulic motor |
| 7. <u>Basket Roll Out Will Not Extend or Retract.</u> | |
| Inspect mast bearings on roll out | Replace if necessary |
| Locking pins not fully retracted | |
| 8. <u>Unit Continues to Run After Release of “Joy Stick”</u> | |
| Joy Stick handle is sticking | Replace or repair |
| Joy Stick valve is by-passing | Replace |
| Joy Stick valve exhaust port muffler is plugged | Clean or replace |
| Hydraulic unit air motor pilot valve is sticking | Clean or replace |
| Base control valves are sticking or by passing. | Replace |

TITAN SCISSOR LIFT

MAINTENANCE

9. Air Motor Not Running or Running Slow

Motor temperature excessively hot.

Lack of lubrication.

Motor will not run.

Check air supply/muffler.

Check lubrication.

Replace motor.

Runs normally then slows.

Confirm 100 PSI air pressure and 80 CFM. Defective air motor/replace.

Low Torque.

Lack of lubrication, misalignment, internal corrosion, inadequate air pressure.

Low Speed.

Lack of lubrication, misalignment, internal corrosion, inadequate air pressure.

TITAN SCISSOR LIFT

2. GENERAL MAINTENANCE INFORMATION

A. FILTER/REGULATOR

A combination filter/regulator is installed in the base of the unit which filters out contamination and small amounts of moisture from the air supply (See Figure 8 in Drawings & Photographs). This device is equipped with an automatic float valve to drain off normal amounts of moisture. However, if there is too much moisture in the air, the customer will need to install a dryer in the supply line that is feeding the unit. The regulator should be set at 100 PSI.

B. AIR LUBRICATOR

All pneumatic components in the Titan Lift are lubricated by an oil mist lubricator that is installed in the lower base of the unit after the filter/regulator (See Figure 8 in Drawings & Photographs). The oil level should be checked daily and refilled when necessary. The oil mist is important for two reasons: 1. Lubrication and 2. Prevention of surface rust on internal components such as valves and air motors. Whenever adding oil to the lubricator the air supply must be shut off and drained by turning off the safety lockout valve in the unit base (See Figure 4 in Drawings & Photographs). Only good quality air tool oil should be used in the lubricator. If air tool oil is not available, use high quality petroleum based oil with a viscosity of 150-200 SSU at 100 deg. F. (Equivalent to SAE #10). Because some oils have additives which damage pneumatic components never substitute another type of oil. The oil delivery setting on the lubricator of 2 drops per minute is present at the factory and should not need readjustment. The rate can be checked by counting the number of drops of oil per minute in the feed sight dome.

C. ALUMINUM DRIVE WHEEL

In order to reduce the possibility of sparking in an explosive environment, the drive wheels are made of aluminum. These wheels should be inspected periodically for damage or wear and replaced when excessive wear is evident.

D. SAFETY STOPS

The Titan Lift is equipped with a safety device to prevent uncontrolled descent of the basket. The hydraulic cylinders will lock instantaneously in position should a hose break or fail in some manner. This is caused by velocity fuses installed directly to the ports on the cylinders.

TITAN SCISSOR LIFT

H. SUGGESTED PREVENTATIVE MAINTENANCE PROGRAM

ITEM	QTY	MAINTENANCE REQUIRED	FREQUENCY
Lubricator	1	Check level and fill as needed	Daily
Hydraulic Unit		Check oil level	Weekly
Drive wheel flange bearings.	2	Grease Fittings(until excess shows)	1000 Hours
Drive wheel coupling	1	Inspect for signs of wear	120 Hours
Aluminum drive wheel	2	Inspect for sign of excessive wear, replace as needed	1000 Hours
Fasteners		Check for loose fasteners, tighten as needed	1000
Hoses		Visually inspect for wear or damage, replace as needed	1000
Decals		Clean or replace if necessary	As needed
Cleaning		Remove dirt & paint buildup, relube as needed	As needed
Exhaust Valves		Replace	As needed
Air Motor Mufflers		Replace	As needed

TITAN LIFT WARRANTY

12/04

Titan Air Inc. hereby warrants its products against defects in material and workmanship for a period of (13) thirteen months from date of shipment.

Titan Air Inc. reserves the right to replace or repair free of charge, any part proven by Titan Air Inc. to be defective. Prompt notification of defective part must be provided to Titan Air Inc. and the defective part must be returned freight prepaid within (30) thirty days of notification. (Air mufflers not covered by warranty)

Warranty includes only parts supplied by Titan Air Inc. Incidental costs and labor charges shall be the responsibility of others. Locally purchased parts will not be reimbursed w/o Titan Air Inc. prior approval.

All warranty parts are to be obtained from Titan Air Inc. This warranty is void if attempts to correct or repair any alleged defective part or parts are made by unauthorized personnel without Titan Air Inc. written approval.

In no event shall Titan Air Inc. be held liable for any damage, incidental or consequential, arising from the installation, performance or operation of the product.

This warranty supersedes, voids and/or is in lieu of any other verbal or written understanding which may not be in total accordance with this expressed warranty.

TITAN LIFT

PARTS RETURN POLICY

All warranty parts are to be obtained from Titan Air Inc.

Locally purchased parts will not be reimbursed.

When ordering replacement parts, it is important to have the following information available:

- 1. Serial number of the lift (This is on the lift ID plate).**
- 2. Part number or description of part needed.**
- 3. Explanation of failure/defect.**
- 4. Complete shipping and billing instructions.**
 - a.) Ship to address.**
 - b.) Shipping method desired (Regular UPS, Next day air etc.)**
 - c.) Billing address including your purchase order number.**
 - d.) A warranty tag will accompany the replacement part.
The customer shall fill out the information required on the tag and return it with the defective part.**
 - e.) The defective part with return tag must be returned to Titan Air Inc. prepaid within 30 days to receive credit.**

You will be billed for the part(s) immediately. Credit will be issued for warranty parts after the defective part(s) have been returned to the factory.

TITAN SCISSOR LIFT

TITAN CROSS REFERENCE PART NO. AND DESCRIPTION

SUGGESTED SPARE PARTS CUSTOM SCISSOR LIFT

DESCRIPTION/FUNCTION	LOCATION	TITAN PT. NO.	QTY/ LIFT
VALVES			
FLOOR MOUNTED MANUAL UP/DOWN CONTROL	LOWER BASE	4-06-50-00352	2
CONTROL AIR SUPPLY VALVE	CONTROL PANEL	4-06-50-00357	1
SYSTEM CONTROL ON/OFF VALVE	GROUND CONTROL	5-06-50-00821	1
E-STOP	BASE & OPERATOR CONTROL PANEL	4-06-50-00358	2
SHUTTLE VALVE	BASE CONTROL	4-06-50-00351	2
LOCKABLE BALL VALVE	BASE CONTROL MAIN AIR SUPPLY	5-06-50-00827	1
JOY STICK CONTROL X-Z AXIS	OPERATOR CONTROL PANEL	4-06-50-00356	2
HYDRAULIC UNIT MOTOR VALVE	BASE	5-06-50-00822	1
BEARINGS			
MAST GUIDE BEARING – ROLL OUT	BASKET BASE	5-06-60-00737	4
DRIVE WHEEL FLANGE BRG.	BASE ASSEMBLY	5-06-01-00803	4
SCISSORS ARM BEARING LOWER	SCISSORS ARM	5-06-80-00669	2
SCISSORS ARM BEARING UPPER	SCISSORS ARM	4-06-20-00043	2
MUFFLERS			
AIR EXHAUST MUFFLERS	E-Stop & Sys Control	4-06-50-00217	3
	Joy-Stick Controls	5-06-50-00818	4
	Air Supply Valve	4-06-50-00346	1
	Hydraulic Unit Air Motor Valve	4-06-50-00349	2
	Base Hydraulic Mtr.	5-06-50-00828	1
HYDRAULIC CYLINDER			
RAISE/LOWER PLATFORM	BASE FRAME	5-06-50-00695	2
WHEELS NON-DRIVEN			
PHENOLIC	BASE	5-06-00638	2
WHEELS NON-DRIVEN/DRIVEN			
ALUMINUM DRIVE SIDE	BASE	5-04-01-00632	2
COUPLING			
HUB FOR HYD MOTOR	IN BASE	5-06-01-00701	2
COUPLING SPIDER	IN BASE	5-06-01-00702	1
HYDRAULIC MOTOR			
	LIFT BASE	5-06-01-00640	1
HYDRAULIC PUMP PACKAGE			
	LIFT BASE	5-06-50-00802	1

AIR MOTORS	MOTOR HYD. PACK		5-06-50-00801	1
FILTER/REG/LUBRICATOR				
	BASE		4-06-50-00127	1
	BASE		4-06-50-00126	1
Quick clamp	BASE		4-06-50-00128	2
Quick clamp & wall bracket	BASE		4-06-50-00129	2
Quick Exhaust Pipe Adaptor	BASE		4-06-50-00328	2
Porting Block	BASE		5-06-50-00820	1
LINE/HOSE TRACK	SCISSORS ARMS		4-06-55-00829	3
			4-06-55-00830	3
			4-06-55-00831	18 FT

TITAN SCISSOR LIFT

REFERENCE DRAWINGS/PHOTOGRAPHS

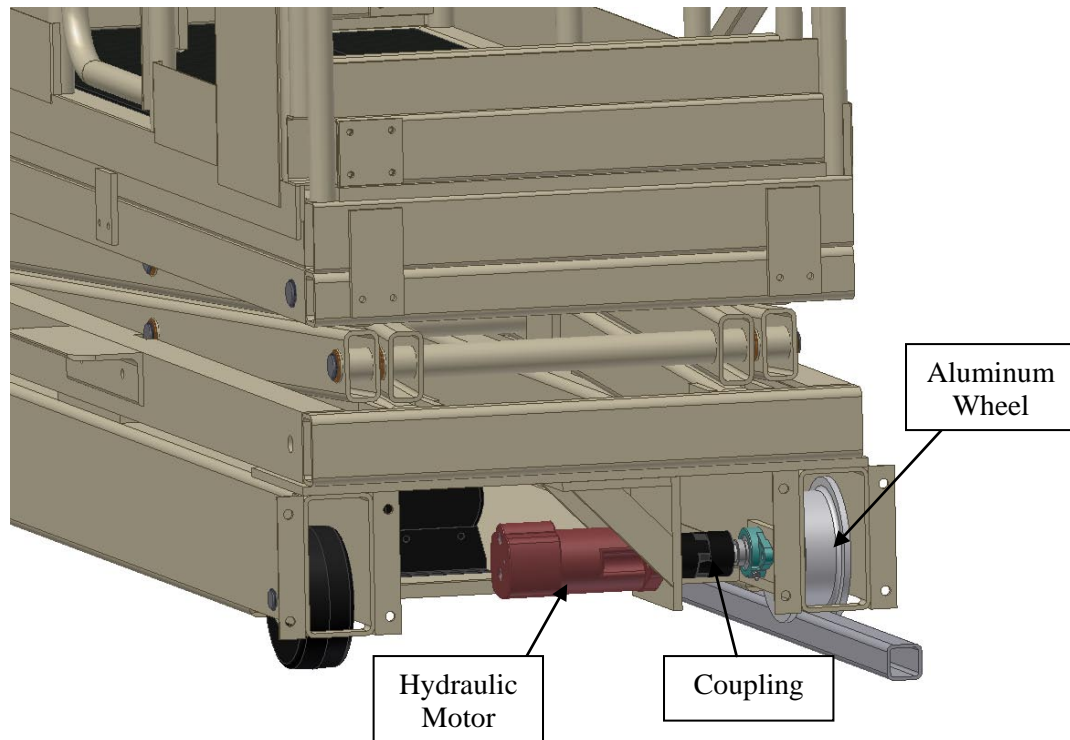

Figure 1

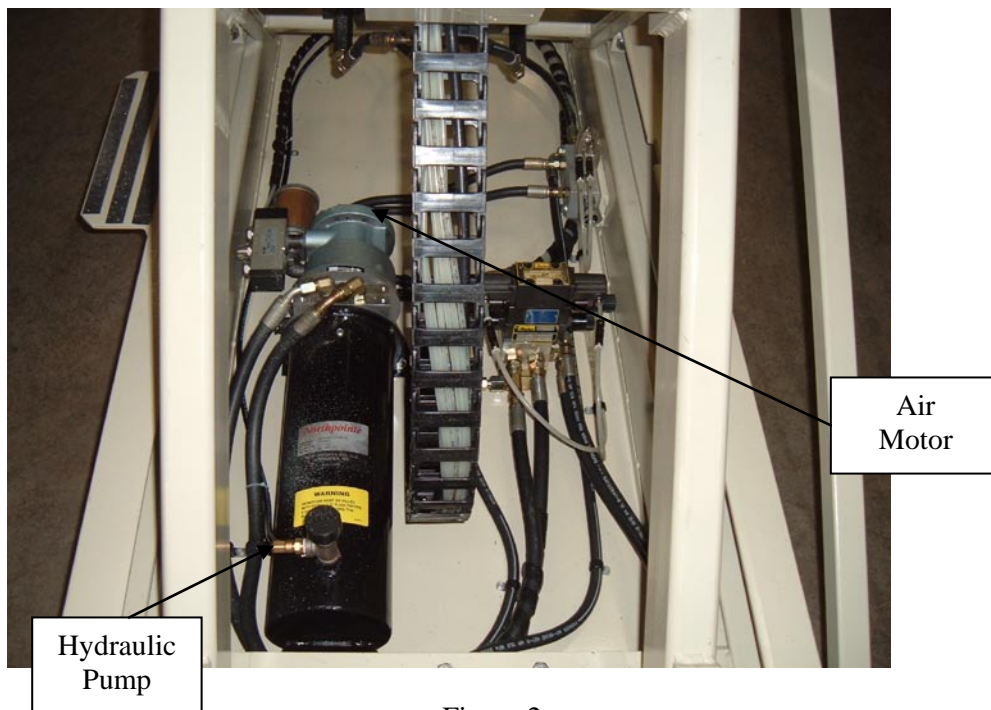
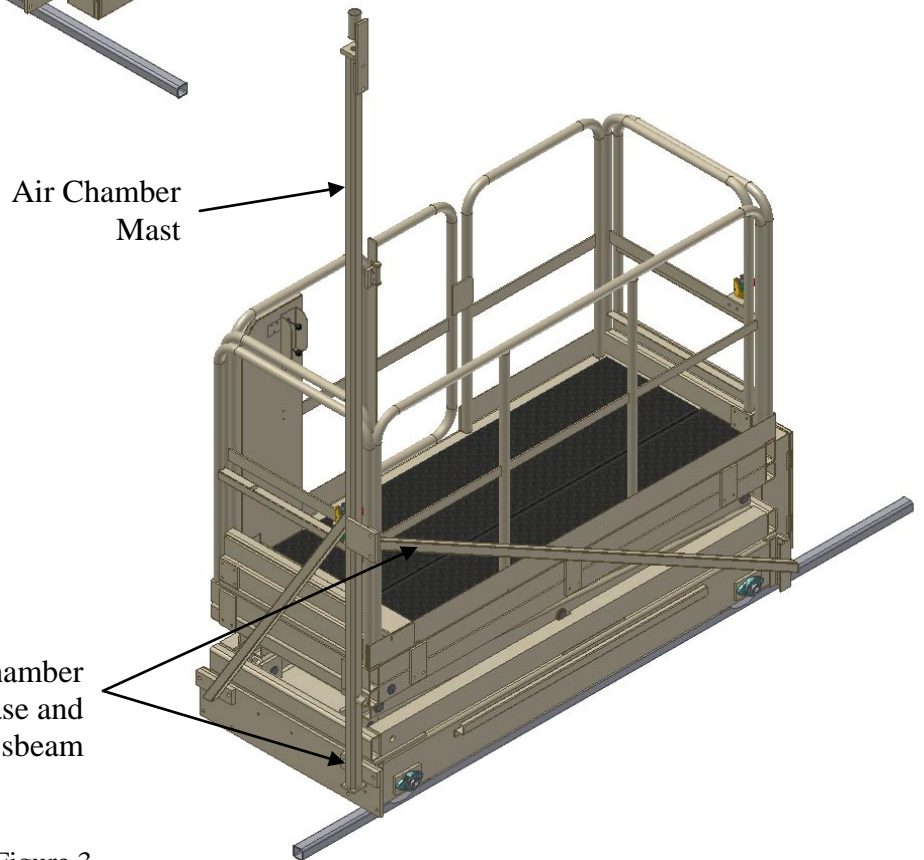
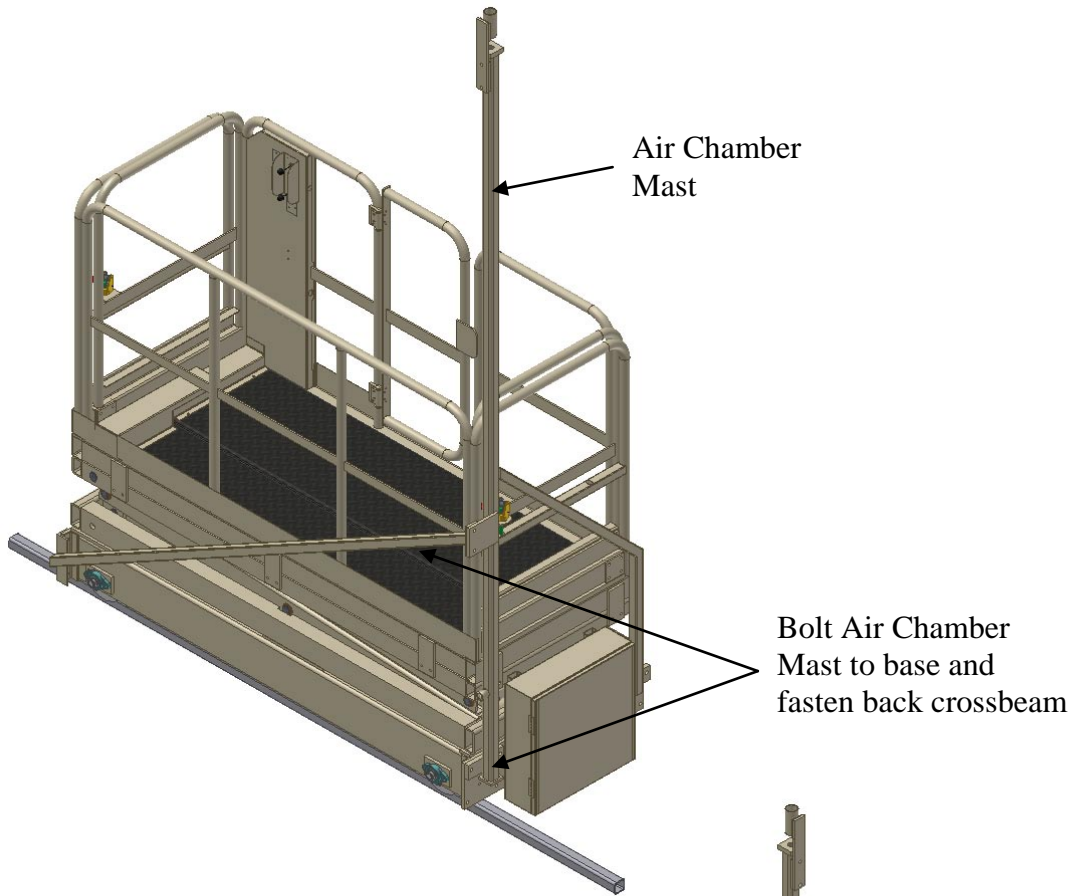

Figure 2



Note:
See "Air Hose Mast
Location Drawing for
more details on how to
orientate lifts in booth.

Figure 3



Air Supply
Shut-Off Valve

Figure 4



Left/Right

Emergency
Stop

Up/Down

Figure 5

Roll-Out
Lock



Figure 6

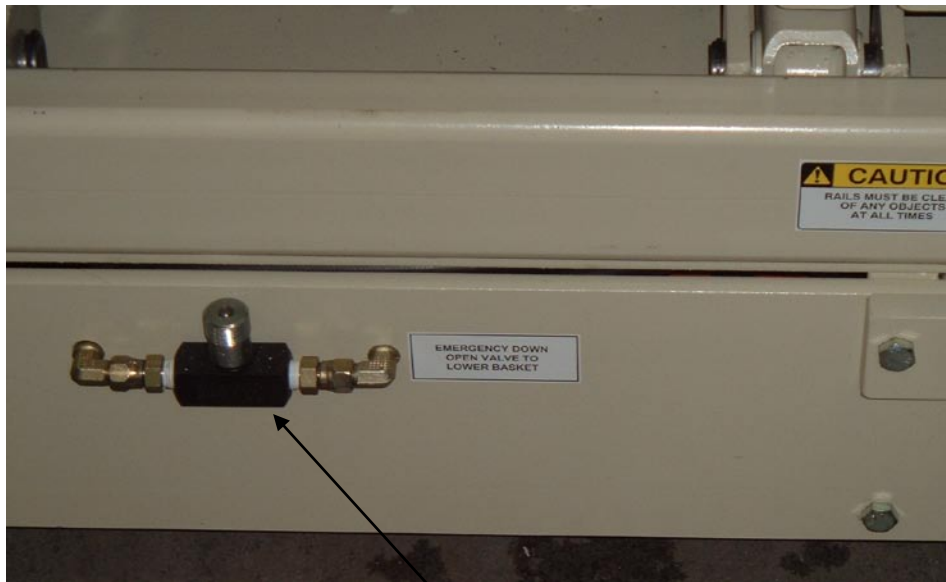

Emergency
Down Valve

Figure 7

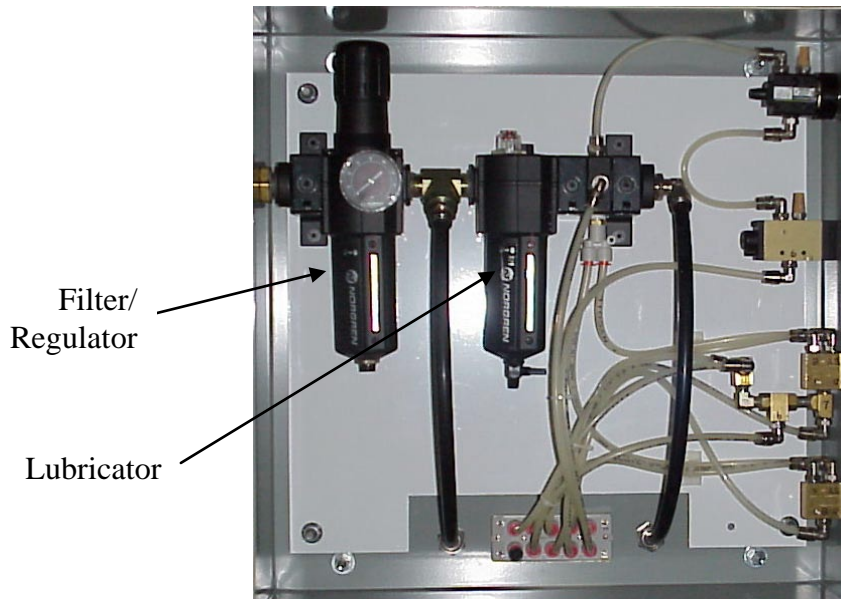

Figure 8