

TITAN LIFT INSTALLATION

1. TOP RAIL INSTALLATION:

The top rail supports (by others) must be in place prior to the lift installation. On a single scissors extension lift, the rail supports must be spaced on no more than 10 Ft. on center and designed to carry no less than 1000 lbs. of horizontal force at the point of top rail connection. On a double scissors extension lift, the rail supports must be spaced no more than 8 Ft. on center and designed to carry no less than 2000 lbs. of horizontal force at the point of connection.

The standard top rail is a W6x15 beam.

- A. Raise the top rail into position. The height of rail must be set at the elevation indicated on the approval drawing.
- B. The rail must be set parallel to the floor.
- C. Weld the top rail to the vertical rail supports (see figure 3). The welds should be continuous $\frac{1}{4}$ " fillet weld around the perimeter of the contact surfaces.
- D. The welding should be performed by Structural Certified Welders only.

2. BOTTOM RAIL INSTALLATION:

It is very important to maintain parallelism between the top rail and bottom track rail. Any excessive misalignment will cause potential binding in the X-Axis drive. In addition, upper rail and bottom track rail must be positioned to insure that the lift is vertical or 90 deg. to the floor. The standard bottom rail is 2" square tubing anchored with $\frac{3}{8}$ " masonry anchor bolts spaced 5 Ft. apart. (see figure 2). If the installation is non-standard, please refer to submittal drawings.

- A. After top rail has been installed, locate the bottom rail tube as shown in figure 1. Drop a plumb line from the outside face of the top rail to the booth floor. The bottom rail tube center line should be between $\frac{1}{8}$ " to $\frac{1}{4}$ " offset toward the booth wall (see figure 1)
- B. Bolt the bottom rail sections in place, butt weld rail sections together & grind flush to assure drive wheels run smoothly across each of the welded joints.

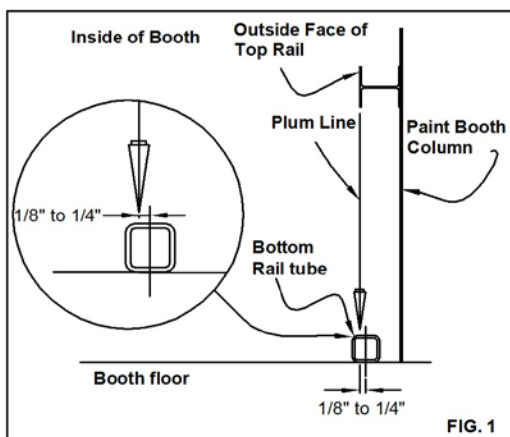

FIG. 1

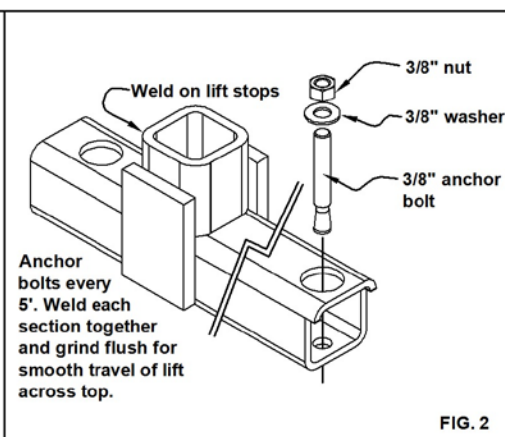

FIG. 2

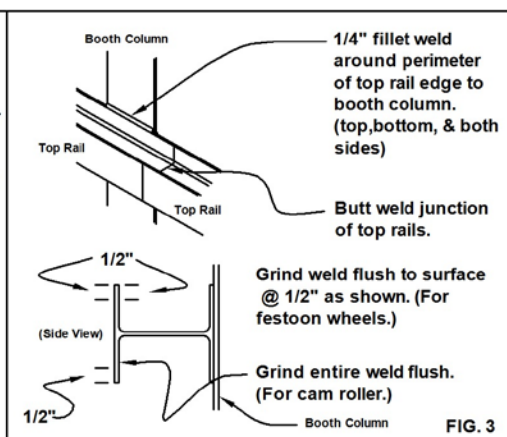

FIG. 3

3. INTERMEDIATE RAIL INSTALLATION:

It is very important to maintain parallelism between the top rail, bottom rail and the intermediate rail. The standard intermediate rail is a W5x16 beam, which is secured to the same supports as the top rail.

- A. Raise the intermediate rail into position. The height of the rail must be set at the elevation indicated on the approval drawing.
- B. The rail must be set parallel to the floor.
- C. Weld the intermediate rail to the vertical rail supports (same as the top rail). The welds should be continuous 1/4" fillet weld around the perimeter of the contact surfaces.
- D. The welding should be performed by Structural Certified Welders only.

4. LIFT INSTALLATION:

- A. A lifting bar is provided (one per job site) for raising the assembly into the vertical position.
Raise the lift into the vertical position & place the aluminum wheels on the bottom rail. Use a forklift or other suitable lifting device with no less than 5000# capacity.
- B. Once the lift has been positioned under the top rail, the cam roller & safety stop assembly can be bolted on the top lift tube (see figure 4), this will lock the lift into operating position. (Caution- until the cam roller assembly is bolted in place, the lift is only being held into the vertical position by the lifting device.) The cam roller assembly bracket includes a 3" channel x 6" long vertical stop (see figure 5). In the event that a cam roller should fail or cam block should fatigue, the vertical stop will prevent the lift from falling forward.
- C. Install the intermediate cam roller assembly on the back of the lift mast by utilizing the pre drilled and tapped holes. The cam roller assembly bracket includes a 6" x 3" wide angle with two cam rollers.
- D. Remove the lift bar from unit and retain for future service requirements or for installing additional lifts on the project.
- E. Attach any items such as rail scrapers, paint pot carriers, etc.

5. UTILITIES

- A. Each Titan Lift requires an air supply of 80 CFM at 100PSI of clean, dry air. Attach air supply hose (supplied with unit) to lift using the hose clamp provided and bolt wire rope hose support to the hole in the top roller mount (see figure 6).
NOTE: Install the air hose avoiding any kinks or bends that would restrict the air supply to the unit.
- B. Fill the air lubricator located at the base of the lift with oil supplied with the unit.

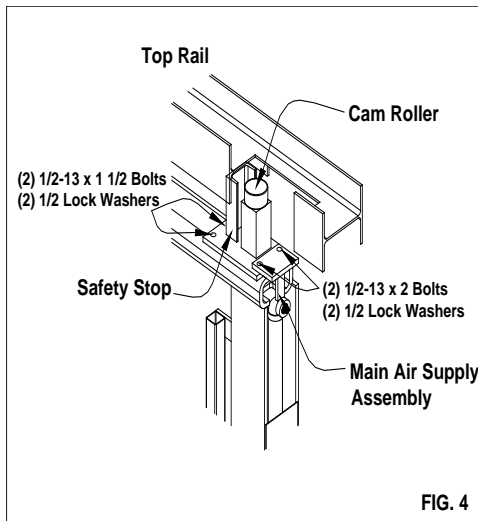

FIG. 4

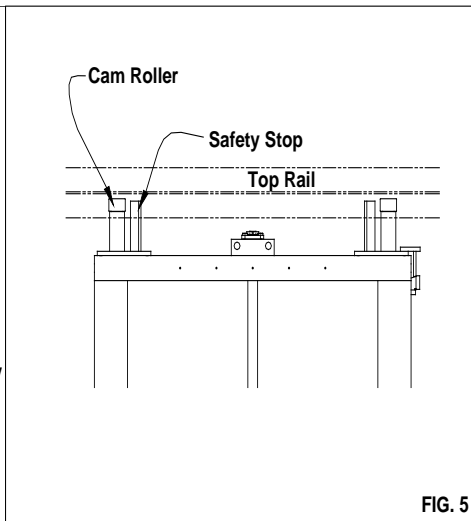

FIG. 5

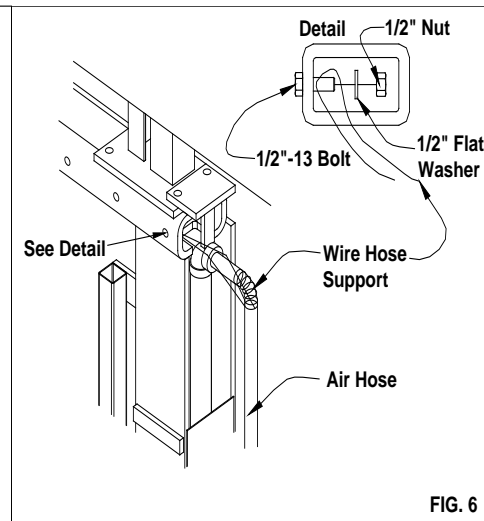

FIG. 6

6. LOAD RATING

A. The maximum load allowance in the basket for standard lifts is 500 lbs. This includes the operator & all related equipment in the basket (live load). Double extension lifts and lifts with special sized baskets are restricted to 350 lbs. Refer to rating plate attached to the lift.